

Veris 480 Volt, 100 Amp, 3-Phase kW Power Transducer Connection Instructions

For use with HOBO® H22, U12, U30 series data loggers, and HOBO data nodes

Applies to this Veris kW Power Transducer:

Onset Part No.	Rating	Output	Veris Part No.
T-VER-8044-100	208-480 Volt, 100 Amp	4-20mA representing 0 to 83.14 kW	8044-0100-2



Installing transducer in an energized electrical enclosure or on any energized conductor can result in severe injury or death. This transducer is for installation by qualified personnel only. To avoid electrical shock, do not perform any installation or servicing of this transducer unless you are qualified to do so. Disconnect and lock-out all power sources during installation and servicing. Please read transducer user's manual for instructions and use.

This document provides instructions on connecting the Veris kW Power Transducer listed above to each of the following:

- FlexSmart™ Analog Module used with HOBO H22 series data loggers
- Analog Sensor Port used with HOBO U30 series data loggers
- 4-20mA cable used with the U12 series data loggers and ZW series data nodes

It also lists configuration values used by HOBOWare® Pro software to configure the logger for the transducer. **Note:** For information on connecting the kW power transducer to the power source, and other transducer details, refer to the documentation provided by Veris.



Veris kW Power Transducer

Required:

- Veris kW Power Transducer listed above
- HOBO H22, U12, or U30 series data logger, or HOBO data node (ZW series)
- FlexSmart Analog Module, Onset Part No: S-FS-CVIA (for H22 series); Analog Sensor Port option (for U30 series); 4-20mA cable, Onset Part No. CABLE-4-20mA (for U12 or ZW series)
- HOBOWare Pro Software, version 2.2.1 or higher (2.4.0 or higher for U30 series; 3.0 or higher for ZW series)
- Customer-supplied length of 18 AWG, shielded, twisted pair cable (Belden 1120A or equivalent recommended)

Configuring the Data Logger for the kW Power Transducer, using HOBOWare Pro Software:

HOBOWare Pro software provides a configuration file for the transducer. To load this configuration file, follow the steps below. For additional information on configuration files, refer to the software documentation.

Channel Name	Warm Up	Measurement Type	Raw Value 1	Raw Value 2	Raw Units	Scaled Value 1	Scaled Value 2	Scaled Units
Power	0.1 sec	Current	4	20	mA	0	83.14	kW

Note: Excitation power provided by the FlexSmart Analog Module (Onset Part No. S-FS-CVIA) with H22; by the Analog Sensor Port with U30; and by power adapter (Onset Part No. AC-SENS-1) with ZW or U12

Connecting the Veris kW Power Transducer to the Analog Module or Port:

See the following pages for applicable connection diagrams that correspond to your electrical power configuration.

H22 Typical 240 VAC Single-Phase Three-Wire Connection

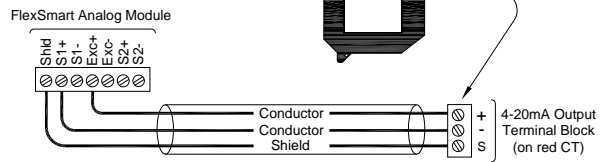
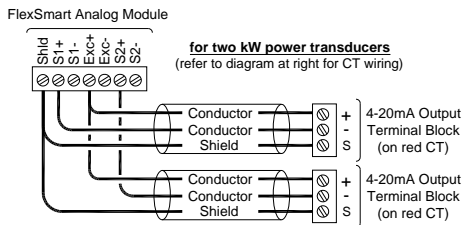
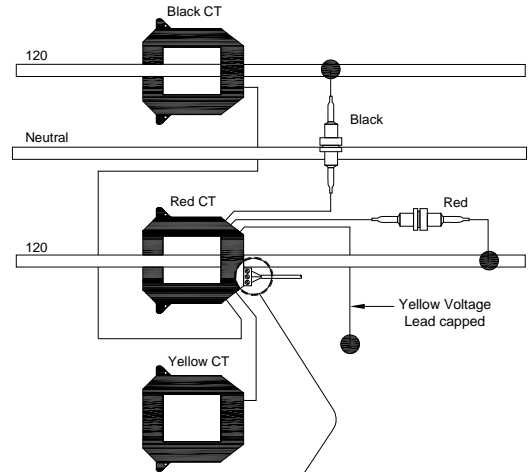
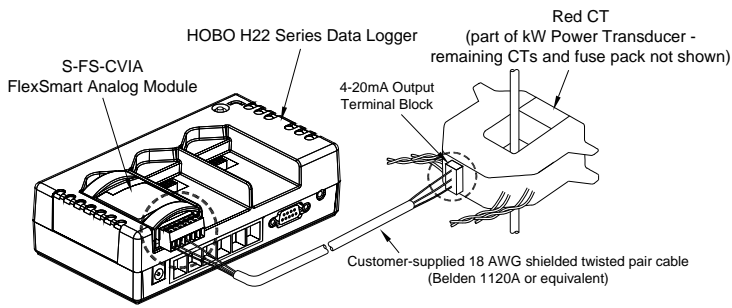

H22 Typical 208 or 480 VAC Three-Phase Three/Four-Wire Connection

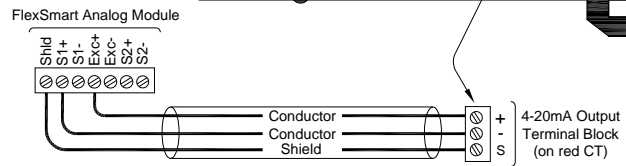
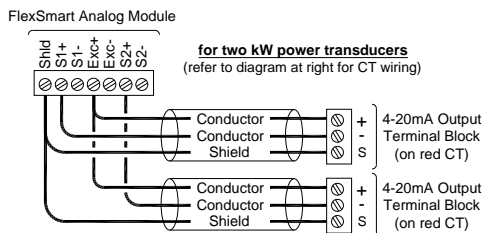
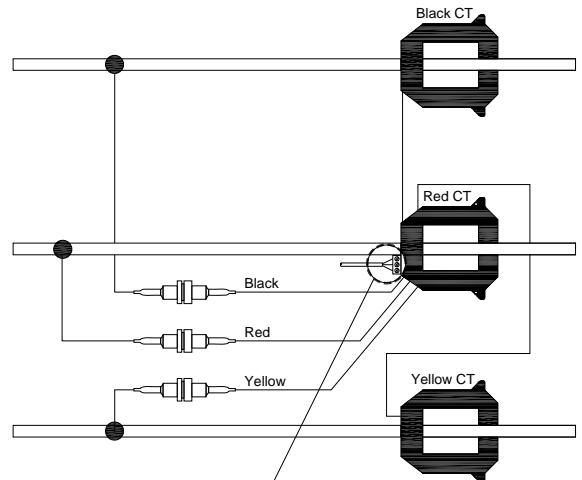
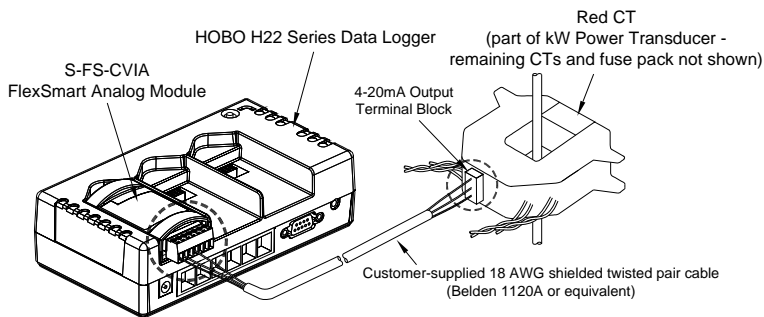

H22 Typical 277 VAC Single-Phase Two-Wire Connection

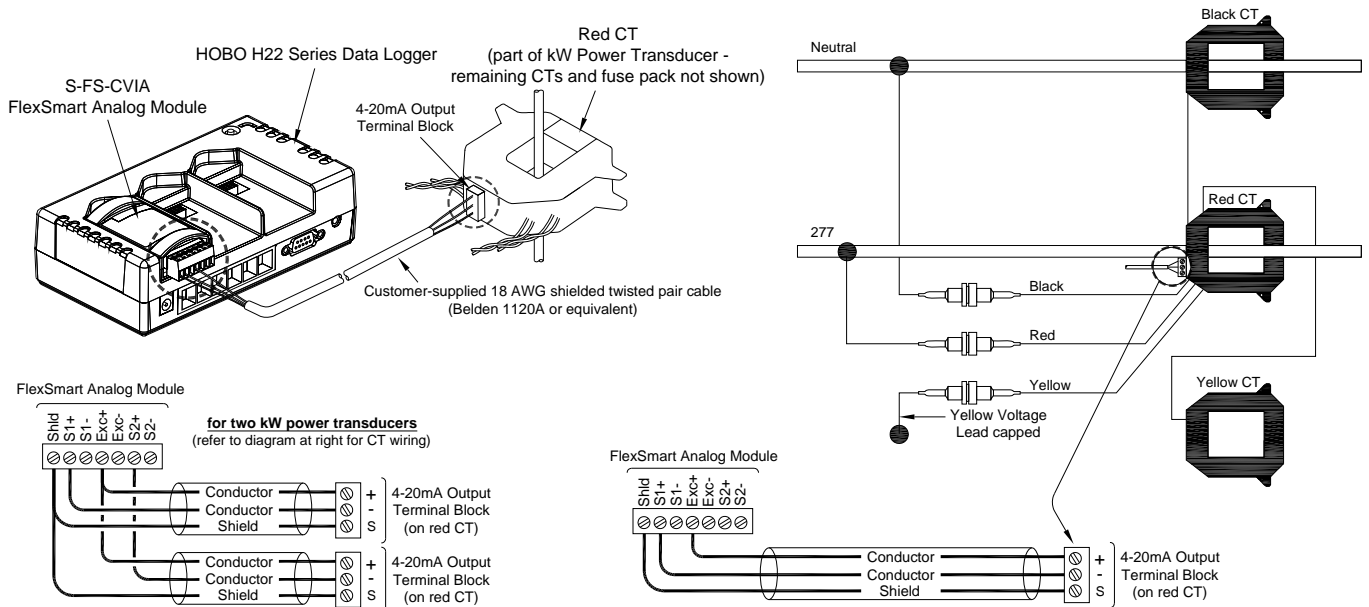

U30 Connection

(also refer to the appropriate CT wiring diagram in the H22 connection section for your particular electrical power configuration)

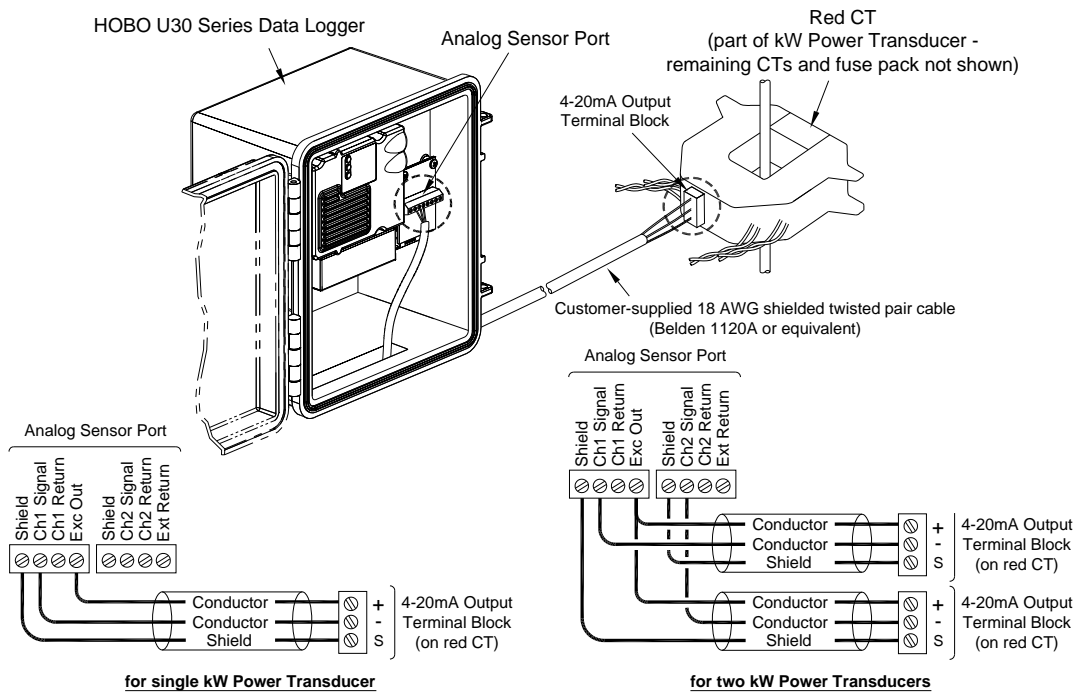

ZW and U12 Connection

(also refer to the appropriate CT wiring diagram in the H22 connection section for your particular electrical power configuration)

